

Posts

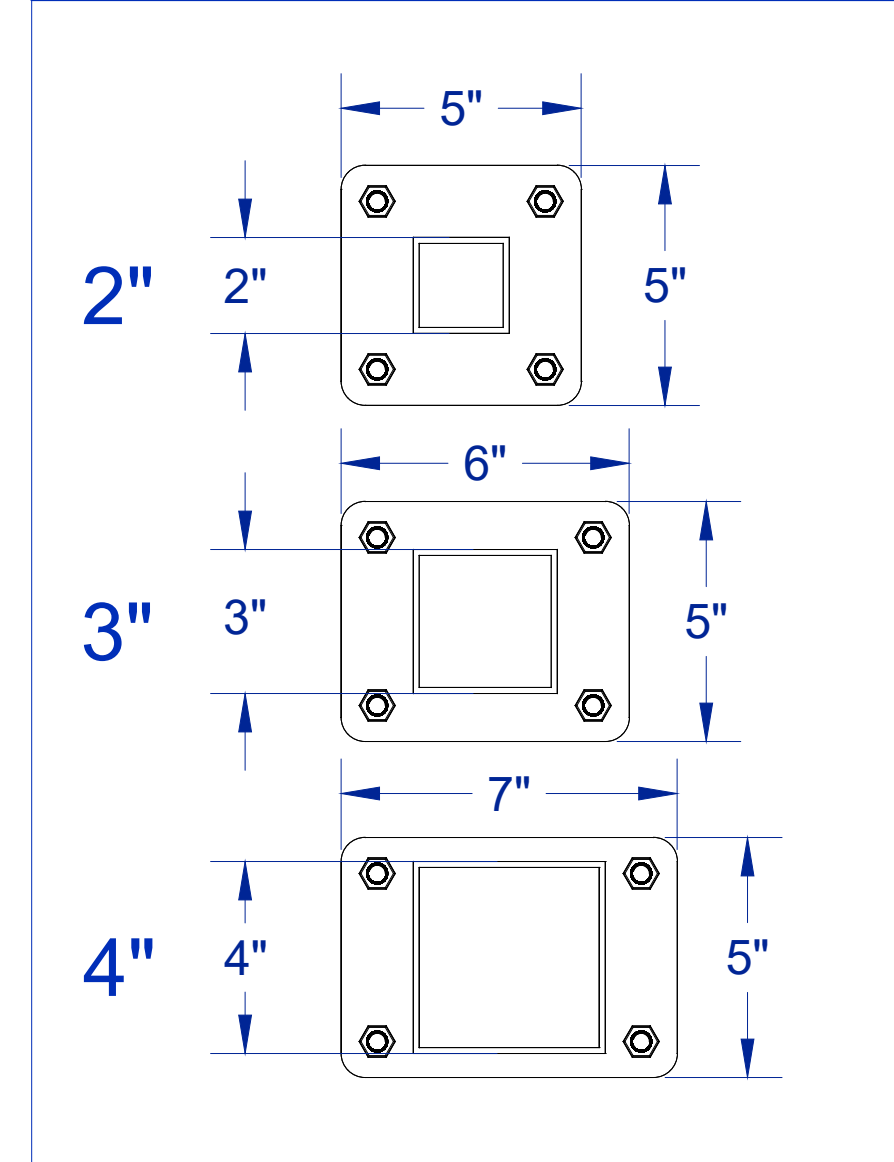

Post Caps

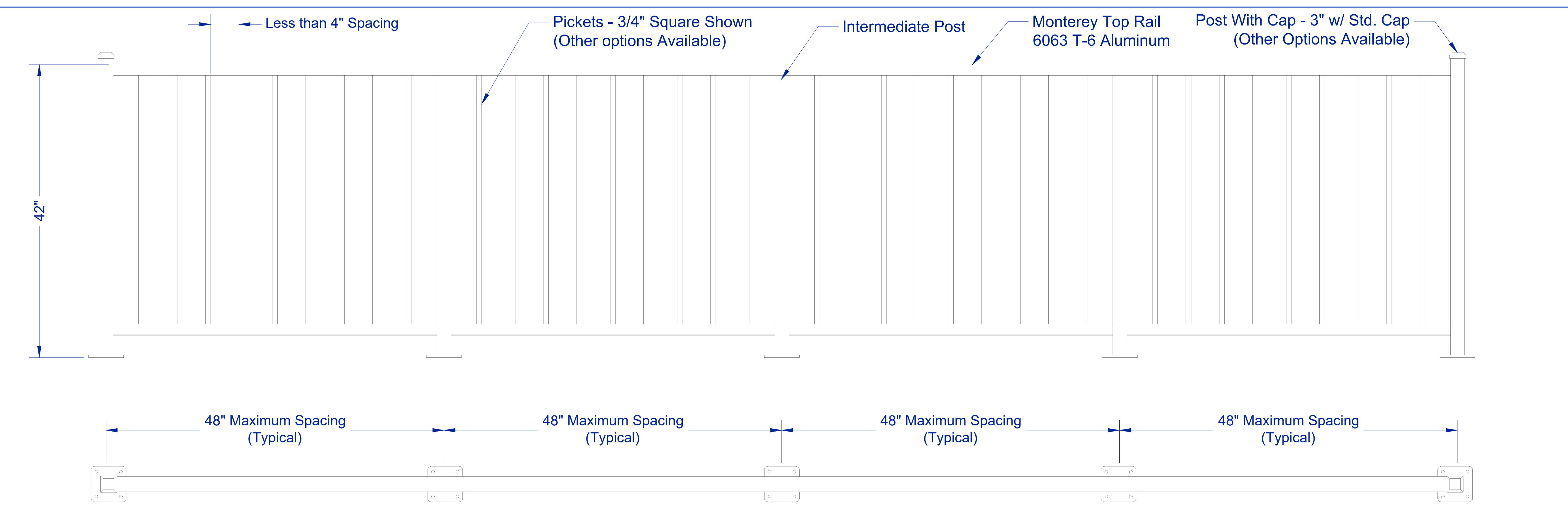
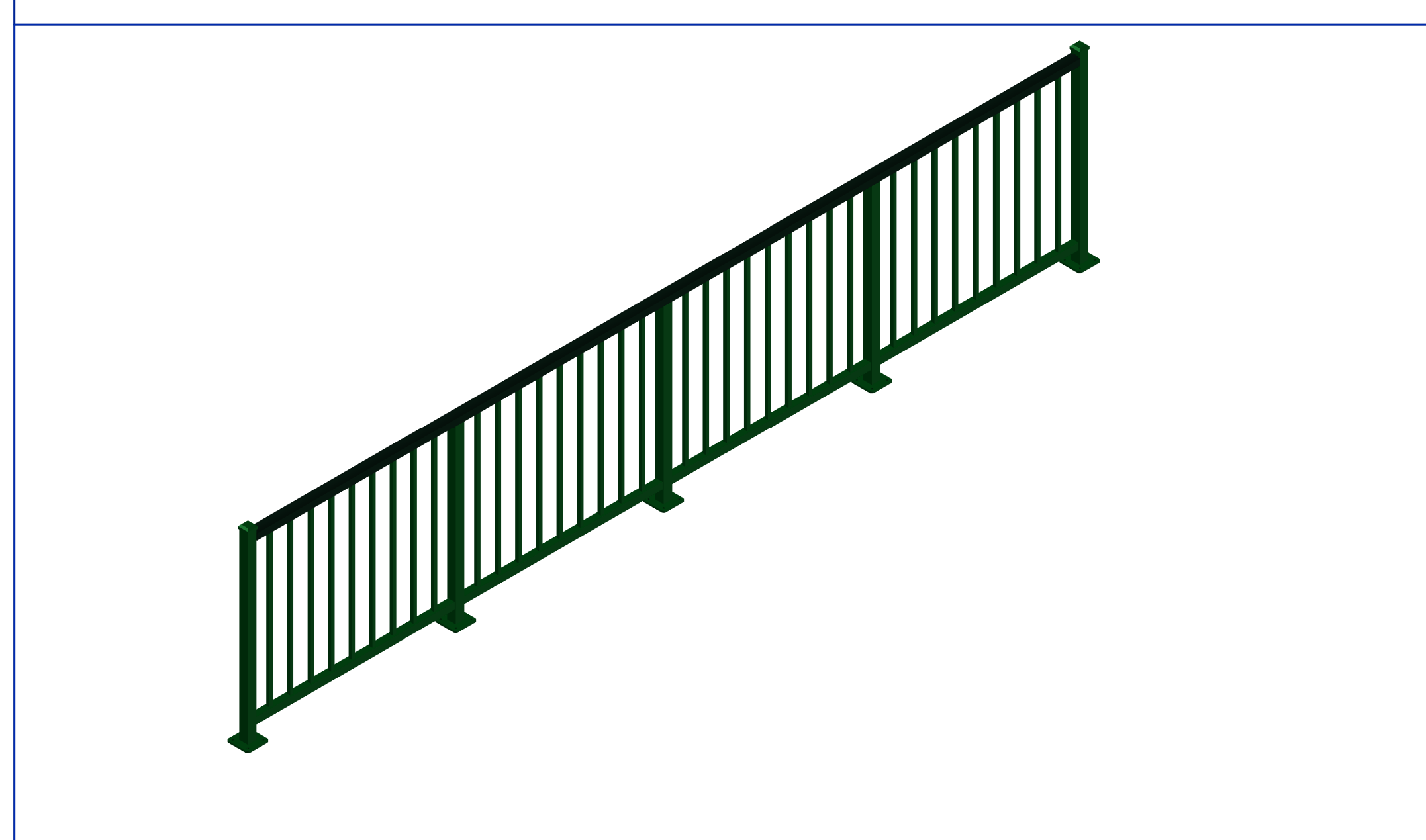
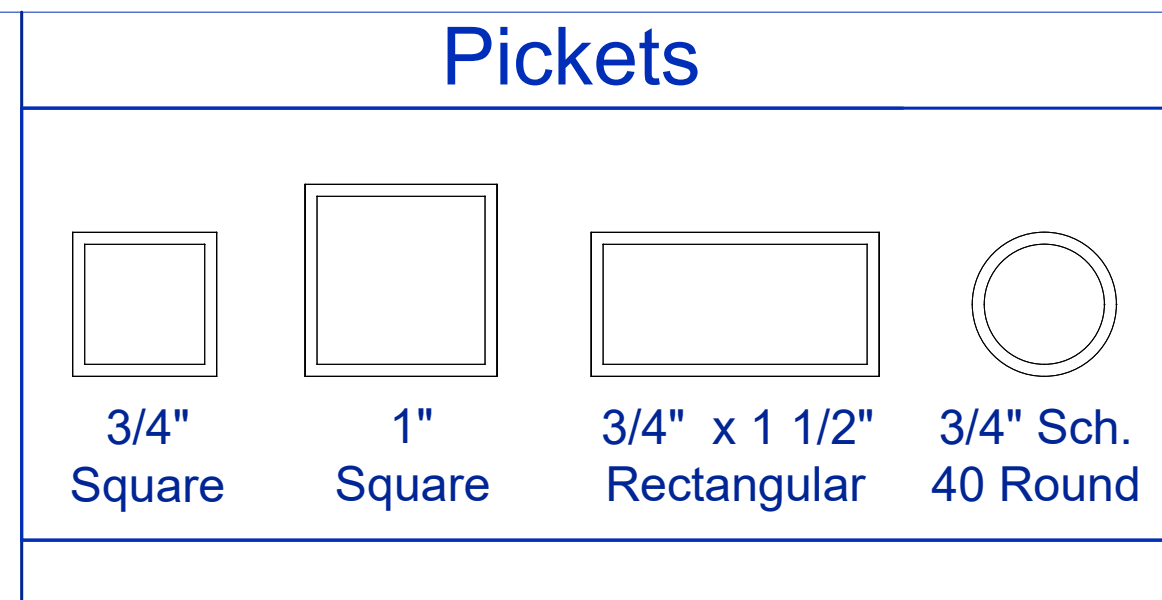
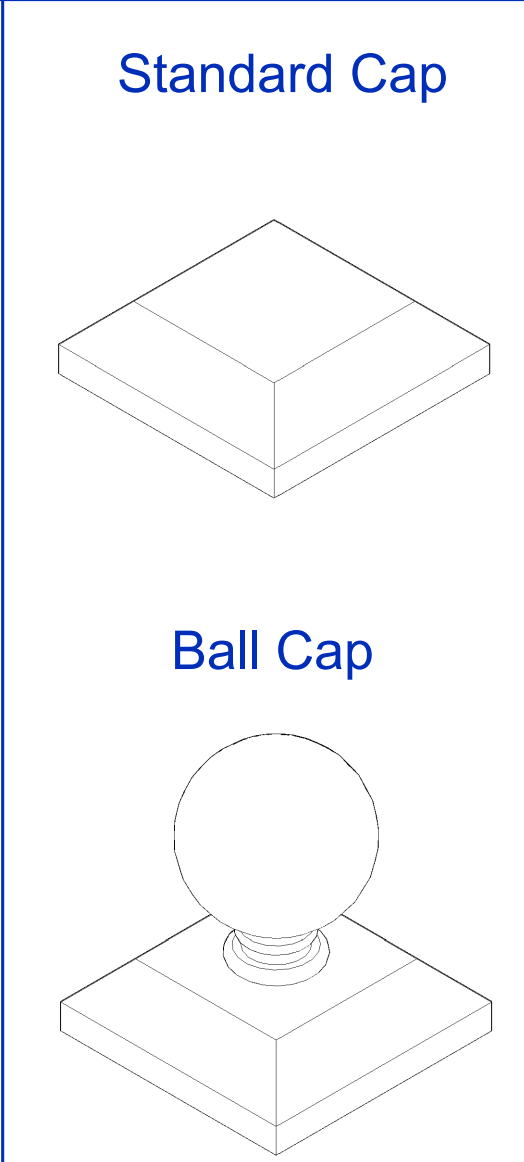

FAIRWAY
ARCHITECTURAL RAILING SOLUTIONS

2075 East State Street
Trenton, NJ 08619
Phone: (609) 890-6600
www.FairwayArchitectural.com

Project:

Architect:

Engineer:

Contractor:

Detail:
Railing Details - Commercial

Model:
Monterey

Revision:	R0
Date:	01 / 2022
Drawn By:	SDR
Approved By:	R Blackman